

Example of designation of the AHH brake with the drum diameter of $D_H=250$ with the ZE 500/50 S500. 400 V AC/50 Hz electrohydraulic thruster, size of 264 (marking see page B1-3):
250-ZE 500/50 S500.400 V AC/50 Hz-264 AHH Drum brake

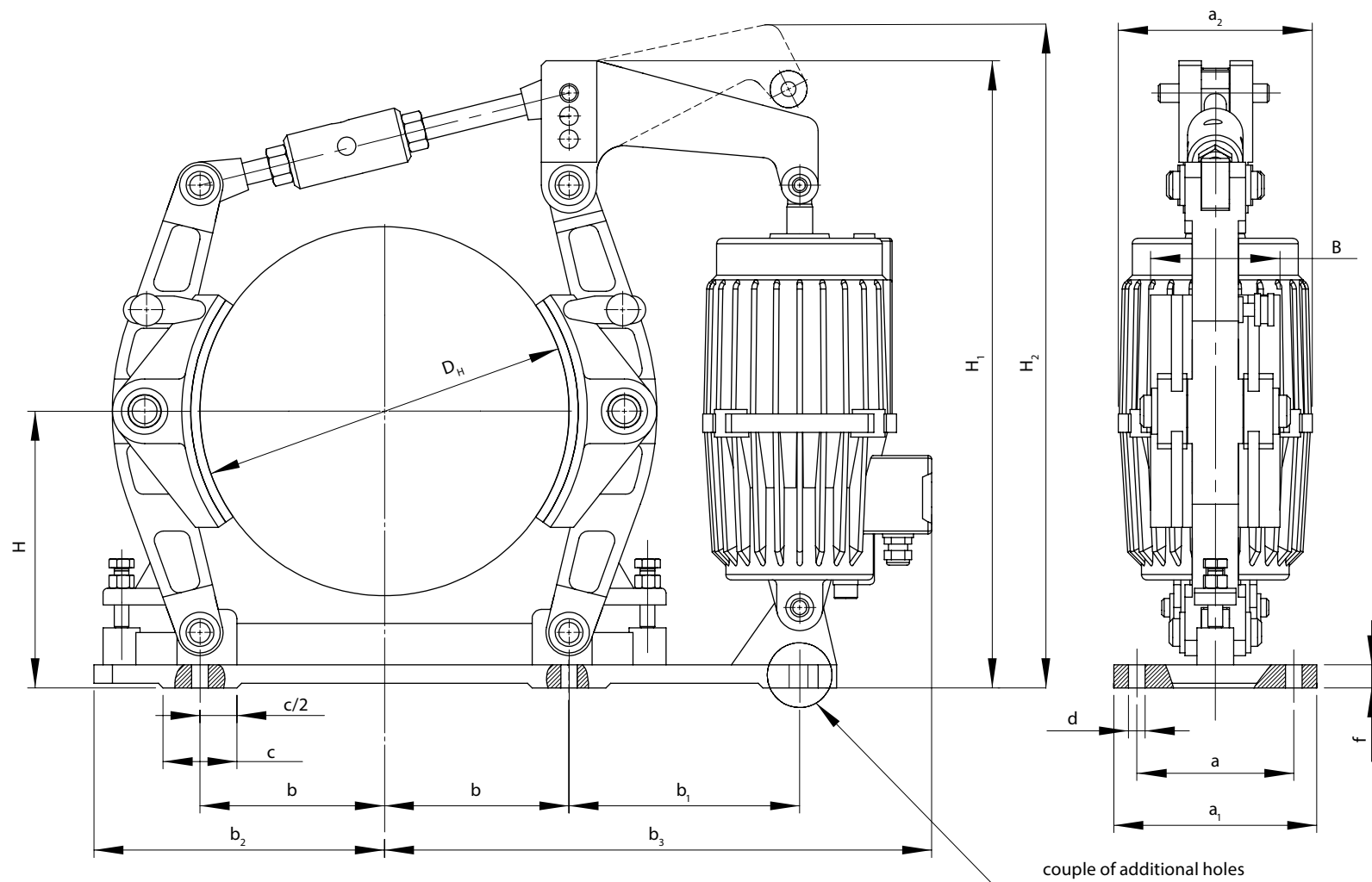

TECHNICAL CHARACTERISTICS

Brake drum diameter D_H	Braking torque M_H	Thruster type	Thruster supply ²⁾ 50 Hz	Brake weight with thruster ³⁾	Brake size and type
mm	Nm	-	V	kg	-
120	20÷50	ZE 120/50-2 S 120	3×230 3×400 3×500	21	261 AHH
160	50÷100	ZE 120/50-2 S 220		26	262 AHH
	80÷160	ZE 500/50 S 320 ZEW 500/50 S 320 ZEM 500/50 S 320 ¹⁾		31	
200	90÷190	ZE 500/50 S 320 ZEW 500/50 S 320 ZEM 500/50 S 320 ¹⁾		44	263 AHH
250	190÷365	ZE 500/50 S 500 ZEW 500/50 S 500 ZEM 500/50 S 500 ¹⁾		52	264 AHH
320	310÷590	ZE 500/50 S 500 ZEW 500/50 S 500 ZEM 500/50 S 500 ¹⁾		85	265 AHH
400	580÷1160	ZE 1250/60 S 800 ZEW 1250/60 S 800 ZEM 1250/60 S 800 ¹⁾		98	266 AHH
500	1000÷1570	ZE 1500/60 S 1250 ZEW 1500/60 S 1250		156	267 AHH
	1600÷2500	ZE 2500/60 S 2000 ZEW 2500/60 S 2000 ZEM 2500/60 S 2000 ¹⁾		168	
630	2300÷4000	ZE 2500/60 S 2000 ZEW 2500/60 S 2000 ZEM 2500/60 S 2000 ¹⁾		255	268 AHH
710	3100÷5000	ZE 2500/60 S 2000 ZEW 2500/60 S 2000 ZEM 2500/60 S 2000 ¹⁾		354	269 AHH
800	4800÷7000	ZE 3200/80 S 2500 ZEW 3200/80 S 2500 ZEM 3200/80 S 2500 ¹⁾		440	270 AHH

We are also offering tailor-made special versions.

¹⁾ When utilising the ZEM... type thruster it is necessary to provide electromagnet supply (38 V DC, current intensity of 0,4 A, for ZEM 500, 0,45 A for ZEM 800 and ZEM 1500; 0,8 A for thruster ZEM 2500 and ZEM 3200).

²⁾ Thruster with different voltage rating and frequency can be made after consultation.

³⁾ Brake weight with oil thruster.

DIMENSIONS

Brake shoe width B	H	H ₁	H ₂	b	b ₁	b ₂	b ₃	a	a ₁	a ₂	c	d	f	Brake size and type
mm														-
40	110	360	410	55	160	115	395	75	105	162	50	14	12	261 AHH
50	130	420 ¹⁾ 457	430 ¹⁾ 505	80	190	145	395 ¹⁾ 375	75	120	162 ¹⁾ 180	60	14	12	262 AHH
70	180	470	505	95	140	190	405	90	130	180	60	18	15	263 AHH
90	220	515	575	120	170	215	440	120	160	180	80	18	15	264 AHH
110	250	585	600	160	220	280	515	140	190	180	80	18	20	265 AHH
140	300	680	690	200	250	315	593	170	220	210	80	18	25	266 AHH
180	360	820	830	250	280	380	673	200	270	210 ²⁾ 254	80	22	25	267 AHH
225	450	1025	1035	325	280	475	762	230	300	254	100	22	30	268 AHH
255	500	1210	1220	370	365	500	892	260	320	254	100	23	30	269 AHH
280	560	1275	1285	400	400	580	960	280	360	254	120	33	40	270 AHH

We are also offering tailor-made special versions.

¹⁾ size 262 AHH: dimensions of the brake with the ZE 120/50-2 S 220 thruster

²⁾ size 267 AHH: dimensions of the brake with the ZE 1500/60 S 1250 and ZEW 1500/60 S 1250 thrusters