

# DYNAMIC BALANCING

**Balancing** is a process necessary for correct operation of the device, in which the element rotating at significant speed and of significant mass can cause the negative influence on the operation of entire machine assembly. Balancing is a procedure concerning the diagnostics of the grade of rotor mass distribution and its further correlation through decreasing or increasing the mass, so that the element rotates with acceptable final unbalance specified in **PN-93/N-01359** standard with indicated **G** accuracy class. The course of dynamic balancing is confirmed by our certificate that is attached to all balanced elements. The element subjected to the process of balancing can influence the reduction of vibration, noise and life of other elements of the machine, and at the same time it increases the comfort and quality of device operation.

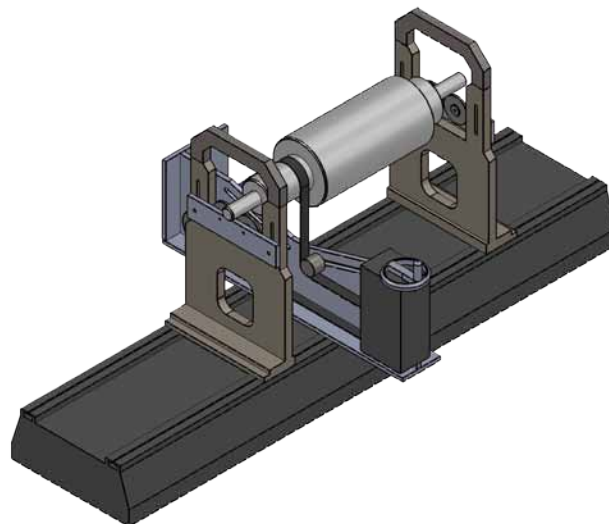

**Applications:** rotors, fans, drums, brake discs, drive assemblies etc.

**Parameters of balancing:** each request for proposal is considered separately, it is recommended to attach the diagrammatic drawing of the element with the specification of parameters of balancing such as:

- class of balancing in compliance with PN-93/N-01359 standard or individual specifications
- mass correction plane (+, -)
- working rotation of the device
- material of balanced element with specification of hardness of surfaces of mass correction planes
- mass

**Parameters of balanced elements:**

