

Example of designation of the SPJ coupling with the nominal torque of $M_n=22000$ Nm, hub hole diameters of $d_1=60$ mm, $d_2=80$ mm, hub hole lengths of $l_1=105$ mm, $l_2=105$ mm, size of 130 (marking see page A6-1):

22000-60/105-80/105-130 SPJ Single-sided gear coupling

Single-sided gear couplings are used in pairs with a spacer shaft.
In cases where journal misalignment is excluded, a single SPJ coupling may be used.

We also offer special designs according to the individual wishes of the customer.

We produce keyways as recommended, normally acc. to PN-70/M-85005, with the Js9 tolerance.

- ¹⁾ Dimension which defines the offset of the cage in order to check the position of the hubs and the state of meshing.
- ²⁾ Higher rotational speeds are possible after consultation.
- ³⁾ The moment of inertia have been determined for the coupling with no holes.
- ⁴⁾ The weight have been determined for the coupling with the pilot bores.
- ⁵⁾ On request, we produce couplings with the lengths of hubs different from the nominal (l_2) lengths given in the table.
- ⁶⁾ Check whether the journal/hub connection will transfer the required torque.

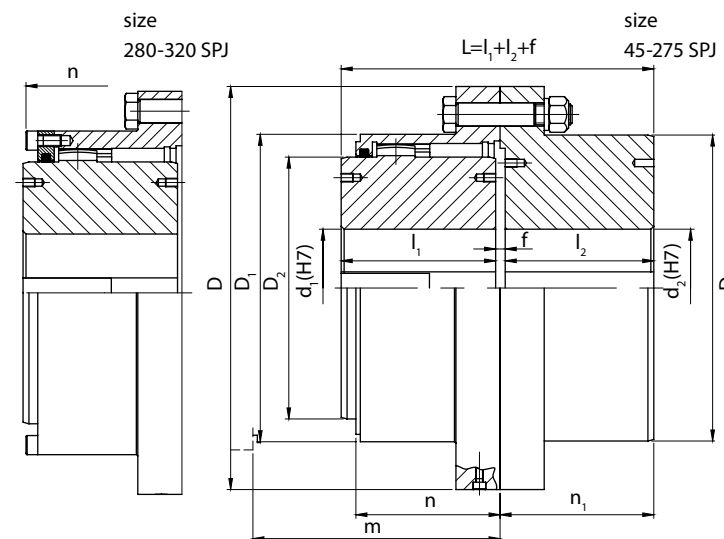

Nominal torque M_n ⁶⁾	d_1, d_2		l_1		l_2 ⁵⁾	f	D	D_1	D_2	D_3	n	n_1	m ¹⁾		Max rotational speed ²⁾	Moment of inertia ³⁾	Weight ⁴⁾	Coupling size and type
	max	nomin.	extend.	nomin.	nomin.								extend.	n_{max}				
Nm	mm													1/min	kgm ²	kg	-	
1300	45	43	80	40	5	111	80	67	80	41	43,5	73,5	81,5	5000	0,005	4,1	45 SPJ	
2800	60	50	114	47	5	141	103,5	87	103,5	47	50,5	83	115,5	4400	0,016	8,2	60 SPJ	
5000	75	62	130	58	5	171	129,5	106	126	58,5	61,5	106	131,5	4000	0,04	14,6	75 SPJ	
10 000	95	76	146	74	6	210	156	130	152	68,5	77,5	124,5	148,5	3600	0,107	26,5	95 SPJ	
16 000	110	90	165	87	6	234	181	151	178	82	90,5	147,5	167,5	3350	0,197	39,6	110 SPJ	
22 000	130	105	170	101	6,5	274	209	178	208	98	104,5	175	175	3100	0,446	60,3	130 SPJ	
32 000	155	120	190	113	6,5	312	247	213	245	108,5	116,5	196	196	2800	0,868	90,3	155 SPJ	
45 000	175	135	200	129	8	337	273	235	270	121	133	220	220	2700	1,362	119	175 SPJ	
62 000	195	150	220	150	8	380	307	263	305	132	154	242	242	2550	2,584	174,3	195 SPJ	
84 000	215	175	250	175	8	405	338	286	330	151,5	179	281	281	2450	3,9	231,1	215 SPJ	
115 000	240	190	280	190	10	444	368	316	362	165	196	308	308	2300	5,65	285,2	240 SPJ	
174 000	275	220	350	220	13	506	426	372	416	183,5	228	344	355	2150	11,446	429,3	275 SPJ	
244 000	280	280	410	280	13	591	472	394	-	225	288	316	447,5	1900	22,6	648	280 SPJ	
290 000	320	292	470	292	14,5	640	518	432	-	234	300	330	467,5	1800	34,5	822	320 SPJ	